

International Conference on Space Optics—ICSO 2018

Chania, Greece

9–12 October 2018

Edited by Zoran Sodnik, Nikos Karafolas, and Bruno Cugny



Mitigating the effect of space small debris on COPV in space with fiber sensors monitoring and self-repairing materials

Emile Haddad

Yi Zhao

Mert Celikin

Matteo Basti

et al.



Mitigating the effect of space small debris on COPV in space with fiber sensors monitoring and self-repairing materials

Emile Haddad^{a*}; Yi Zhao^b; Mert Celikin^b; Matteo Basti^b; Kamel Tagziria^a; Elad Wallach^a; Christopher Semprimoschnig^c; Ugo Lafont^c; Iain McKenzie^c

^aMPB Communications; 151 Hymus, Pointe-Claire (Qc), H9R-1E2, Canada

^bINRS-EMT 1650 Lionel-Boulet; Varennes (Qc), J3X-1S2-Canada,

^cESTEC-ESA- Keplerlaan 1, 2201 AZ Noordwijk, Netherlands,

ABSTRACT

Small space debris are a high risk for the walls of Composite Overwrapped Pressure Vessels (COPV), by making small holes and causing the fuel leak. Commonly the self-healing materials are used to keep the mechanical structure strength, here the hermeticity of the repaired portion is a stringent requirement, to prevent any potential fuel leak from the cryogenic tank in vacuum. The efficiency is compared for protective walls composed of a combination of various layers, using strong materials (Kevlar, Nextel) and self-healing commercial materials developed as bulletproof, e.g. the Ethylene-co-Meth Acrylic Acid (EMAA) and Reverlink™.

The small debris impact dynamic was detected and monitored with Fiber Bragg Gratings (FBG) sensors at very fast acquisition frequencies, up to 0.5 GHz (2 ns), measuring the variation of the total reflected signal by the FBG. The acquisition system is based on commercially available products. To measure the total wavelength spectrum, the fastest available spectrometer can go up to 2 MHz acquisition (Micron-Optics), which is insufficient to detect the hypervelocity impact. The impact pressure evolution of the FBG, placed in the middle layer, was compared with commonly used strain gauges placed a few layers further or on the back of the last layer. The measured impact time delay and relative intensity were compatible between the two sensing methods.

Some samples were characterized in details using the X-ray Computed Tomography at ESTEC, they permitted us to confirm the results by observing the details of the healing and follow the impact trajectory visually.

Keywords: Times Roman, image area, acronyms, references

*emile.haddad@mpbc.ca; phone;1(514) 694-8751 x 224 fax 1(514) 695-7492; www.mpbc.ca

1. INTRODUCTION

The project aims to provide a basic solution to protect the Composite Overwrapped Pressure Vessels (COPV) walls from the space debris and a way to monitor the debris impact using Optical Fiber Sensors.

The presence in space of micrometeoroids and orbital debris, particularly in low earth orbit, presents a continuous hazard to orbiting spacecrafts such as the Space Shuttle and the International Space Station (ISS). Space debris can be defined as all man-made objects, including fragments and elements thereof, in Earth orbit or re-entering the atmosphere, that are non-functional. As the population of debris continues to grow, the probability of collisions that could lead to potential damage will consequently increase. In addition, there is also the risk of damage on the ground, if debris survives Earth's atmosphere upon re-entry. The mitigation of space meteorites is one of six major issues for international consideration by the United Nations Technical Committee on the Peaceful Uses of Outer Space.

The initial impact of debris is a hole, somewhat larger than the debris' diameter, followed by an energetic plume of many hundreds of particles that spread in a defined cone angle to create a damage zone nominally one (or many) order of

magnitude larger than the impact particle diameter. In particular, with composite laminates, a delamination is created internally over a larger area.

The requirements are to prevent space debris from creating a hole or heal it and close it hermetically. The hermeticity is verified with a vacuum test.

We monitor the impact evolution and the healing using FBG sensors. The FBG is a periodical structure that reflects specific wavelength light, proportional to the length of the period and the refractive index.

One wavelength FBGs are commonly used as sensors. Chirped FBGs are sometimes used, as they can have all the periods corresponding to the range of telecom 1520-1565nm.

For the debris impact, the strain is monitored, as the most important effect, while the temperature increase is a much slower process

2. METHODOLOGY

The projects included a few steps

- Select and test self-healing materials
- Calibrate and use a hypervelocity pellet launcher
- Select and embed FBG sensors
- Verify the self-healing hermeticity in vacuum
- Analyze the healed samples with X-ray Computed Tomography to follow the pellet trajectory and the healing

2.1 Self Healing Materials

The efficiency of self-healing of COPV was compared for protective walls composed of a combination of various layers, using healing agent embedded in microcapsules, strong materials such as Kevlar and Nextel; and self-healing commercial materials developed as bulletproof, e.g. the Ethylene-co-Meth Acrylic Acid (EMAA) and Reverlink™. The hermeticity of the repaired portion is a stringent requirement, to prevent any potential fuel leak from the cryogenic tank in vacuum. Microcapsules filled with 5-Ethylene-2-Norborene (5E2N) as those used previously by MPB within composite layers, permitted to repair the small cracks and delamination, around the impact hole, however, they were not efficient as a hermetic layer.

The tradeoff led us to select a multi-layered mixture of two materials:

- a) Self-healing polymers such as Ionomer-EMAA (Ethylene-co-MethAcrylic Acid (bulletproof materials)) or Supra molecule Rubber Reverlink™.
- b) Strong Materials resistant to impact such as Kevlar (polymer-aramid), Nextel (ceramic-glass).

2.2 Launcher and Hypervelocity pellets

To experimentally simulate the small debris impact, we use a double stage launcher (Figure 1) kindly provided by McGill University with Aluminium and Stainless spheres of 2 - 4 mm diameter, providing pellet hypervelocity 1 - 1.7 km/s. The most of the test were made with stainless steel 2mm diameter, which has higher effects than the Al pellets of the same diameter at the same velocity, due to the higher density.

Figure 2 shows a picture of the pellet/sabot and the diaphragm. The magnet bar is used to measure the hypervelocity when it passes between two copper coils separated by 5 cm

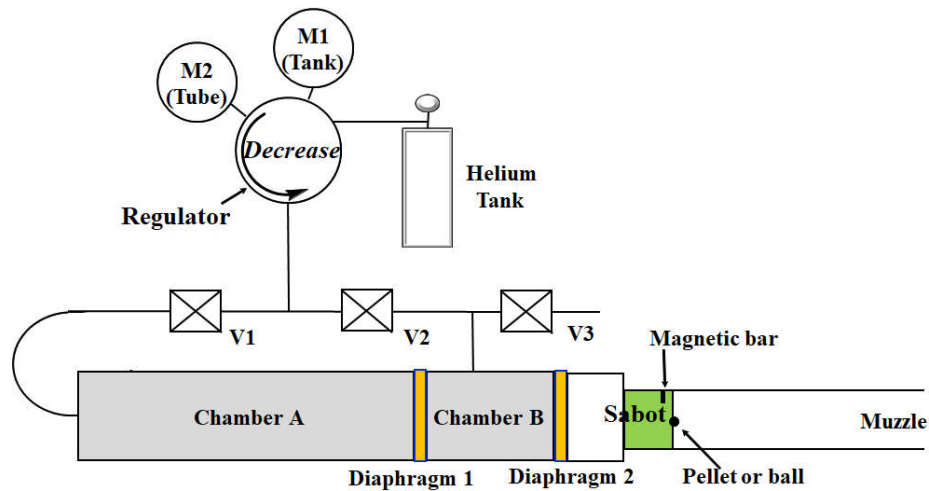

Figure 1. Two stages launcher pressure connection (up to 1.7 km/s; pellets: 1-5mm diameter)

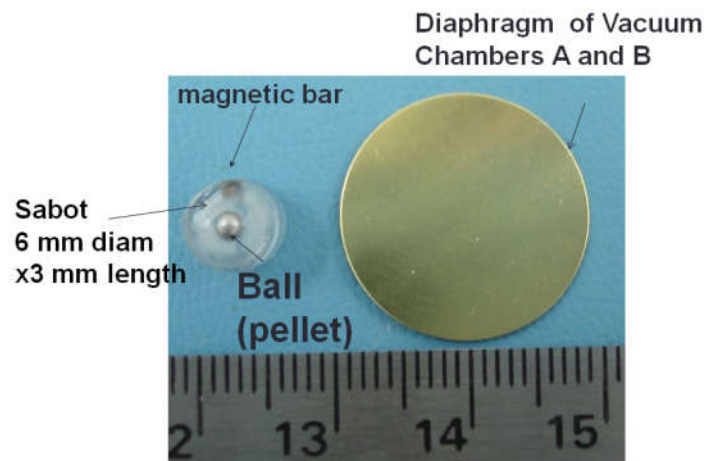

Figure 2. Diaphragm and a pellet (ball) with a sabot

2.3 FBG Sensors

Two types of FBGs were used

- i) a thin central wavelength FBG with 0.5 nm spectral width and 1 cm length similar to those used as Wave Division Multiplexing (WDM) in telecom, it is used as a sensor since the pressure impact proportional to the wavelength shift;
- ii) a chirped FBG covering about 40 nm reflectance range with length about 2.5 - 4 cm long; the position on the grating and the local wavelength are linearly related. A measurement of the complete spectrum of the FBG sensor before and after the impact gives important information in synergy with the fast signal measurements. The hypervelocity impact dynamic is monitored with the change of the FBG reflected intensity, in time and value, permitting the measurement of the local stresses and the destroyed region. Moreover, the slow change of the residual strain and self-healing as well as their localization, are obtained by comparing the detailed reflectance spectra of the sensors, before the test, a few minutes after the test, one day after the test and a few weeks later, for slow evolution.

Figure 3 illustrates Single wavelength sensor submitted to compression expansion in the direction of the fiber. The shape is conserved even with a shift of about 30nm

Figure 4, illustrates Single wavelength sensor embedded in a hard structure and submitted to strain perpendicular to the direction of the fiber. We can see the deformation of the reflection spectra.

Spectrometers for the FBGs have an acquisition speed limited to 2 MHz (MicronOptics), which is slow to catch the hypervelocity impacts (Figure 5)

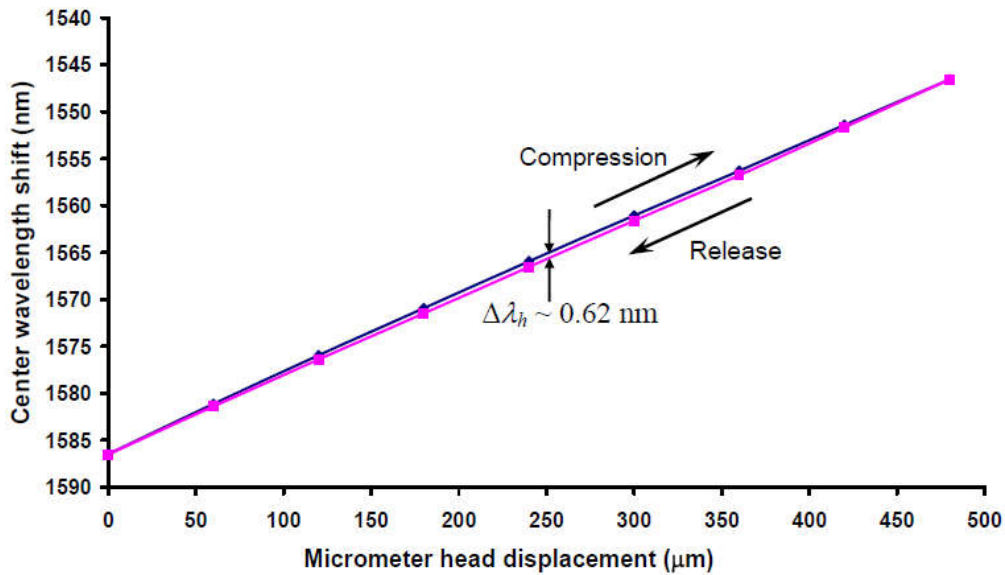
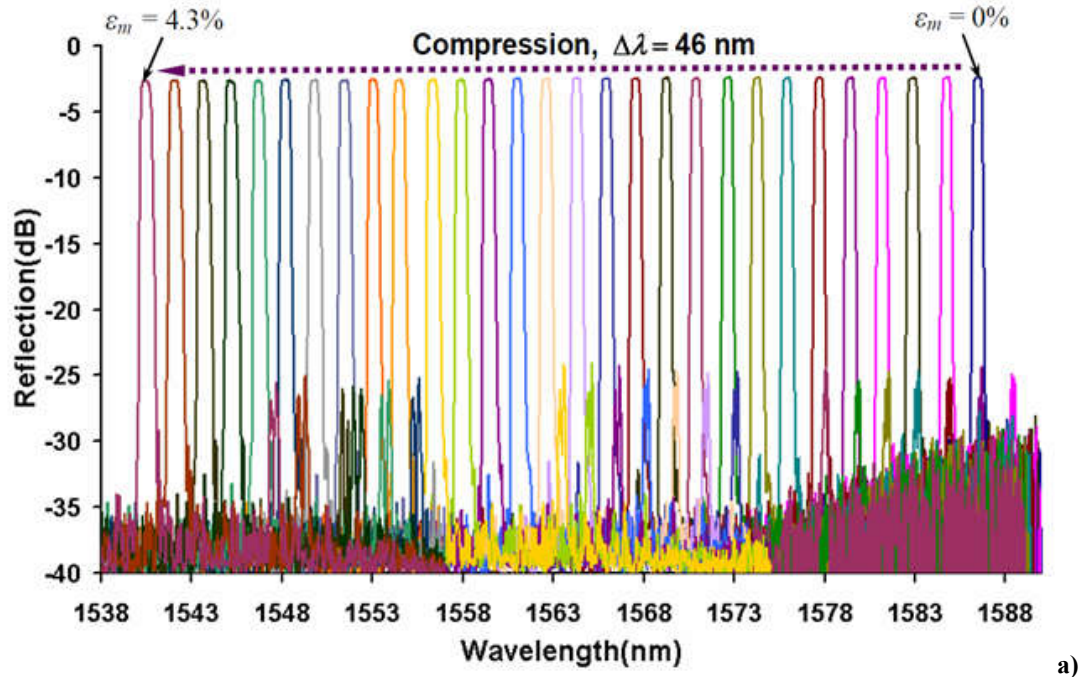

Figure 3. a) Single wavelength sensor submitted to compression expansion in the direction of the fiber, b) Center Wavelength shift and hysteresis with compression-expansion in the direction of the fiber

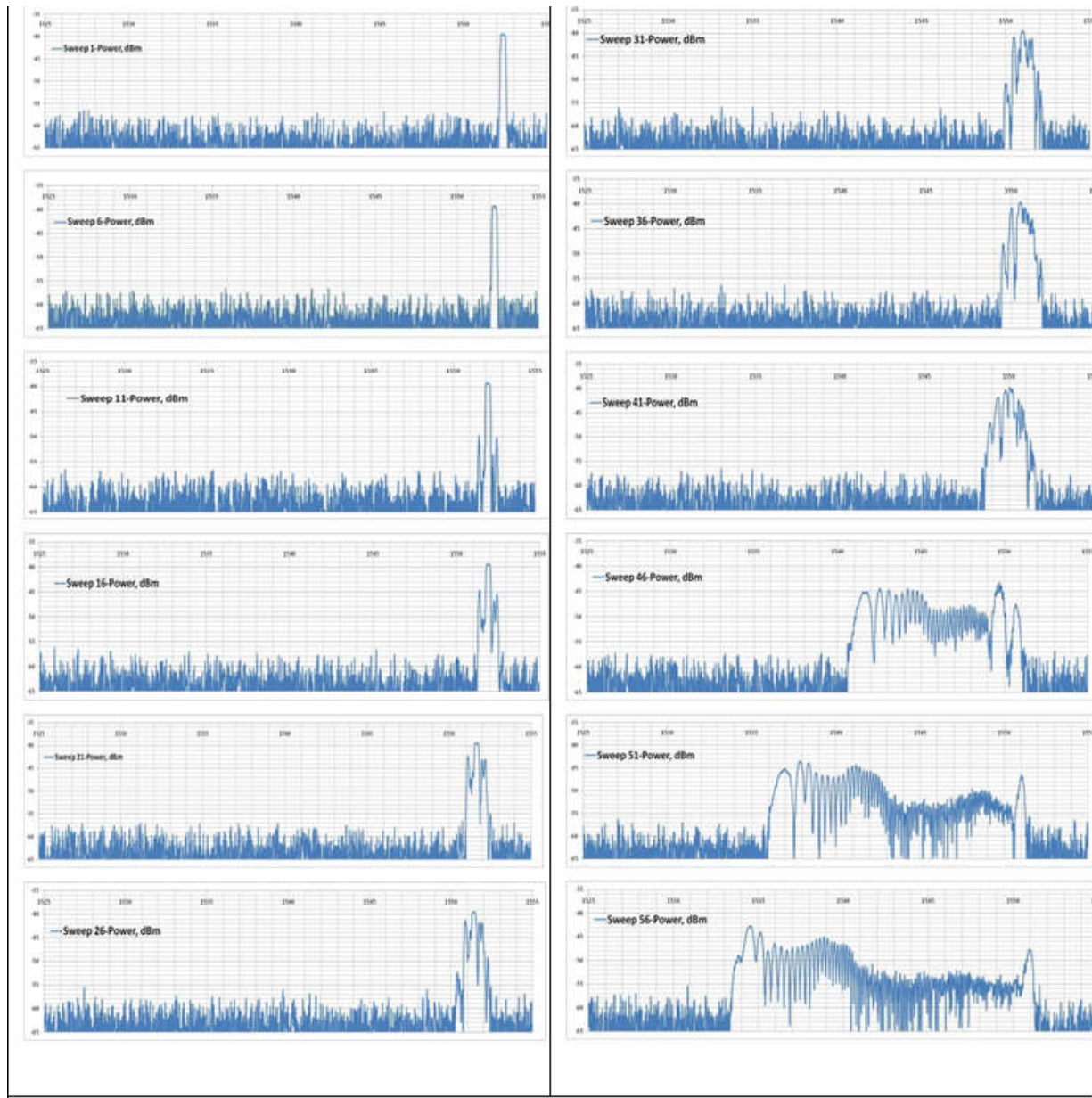

Figure 4. Single wavelength sensor embedded in a hard structure and submitted to compression expansion perpendicular to the direction of the fiber.

We propose to use the total intensity reflected by chirped FBG covering a wide range of wavelength. This intensity after impact is linearly related to the position impacted. The use of total intensity provides a main advantage, it can be measured using faster, simpler and easily available electronic components in GHz levels.

More information can be obtained by measuring the complete spectrum after the shot to see the final status.

Figure 6 and Figure 7 illustrate the linear relationship between the total intensity, the physical length and the wavelength in a plateau chirped FBG.

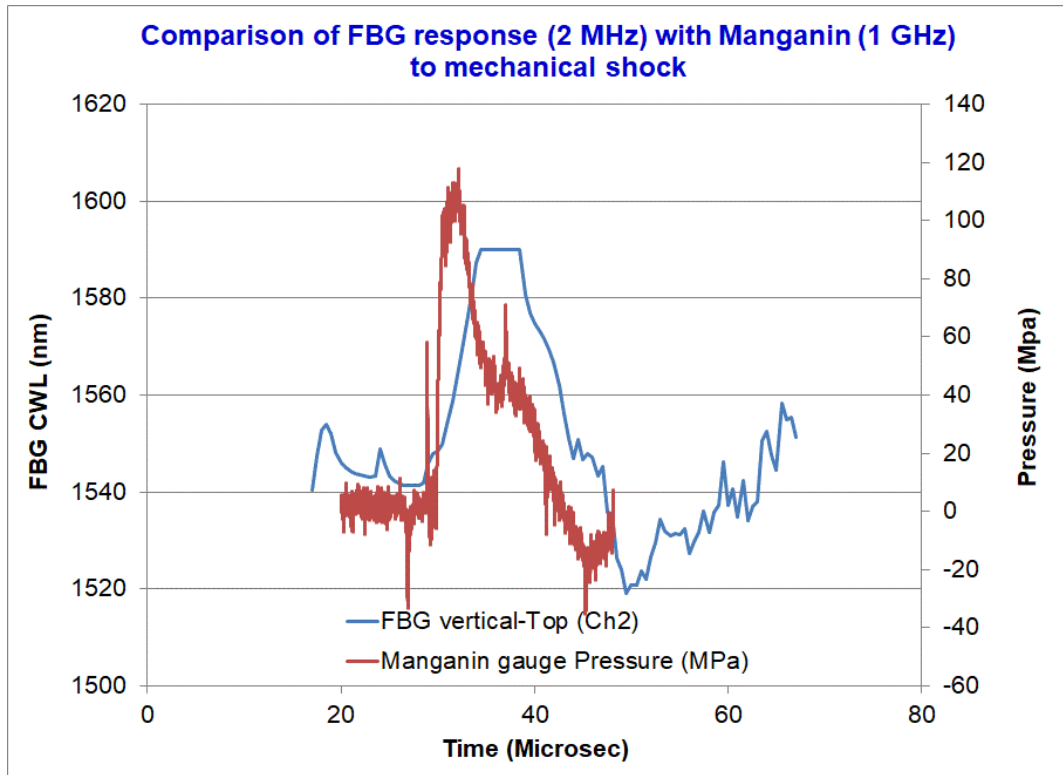

Figure 5. Comparison of the strain gauge and FBG response to mechanical shock

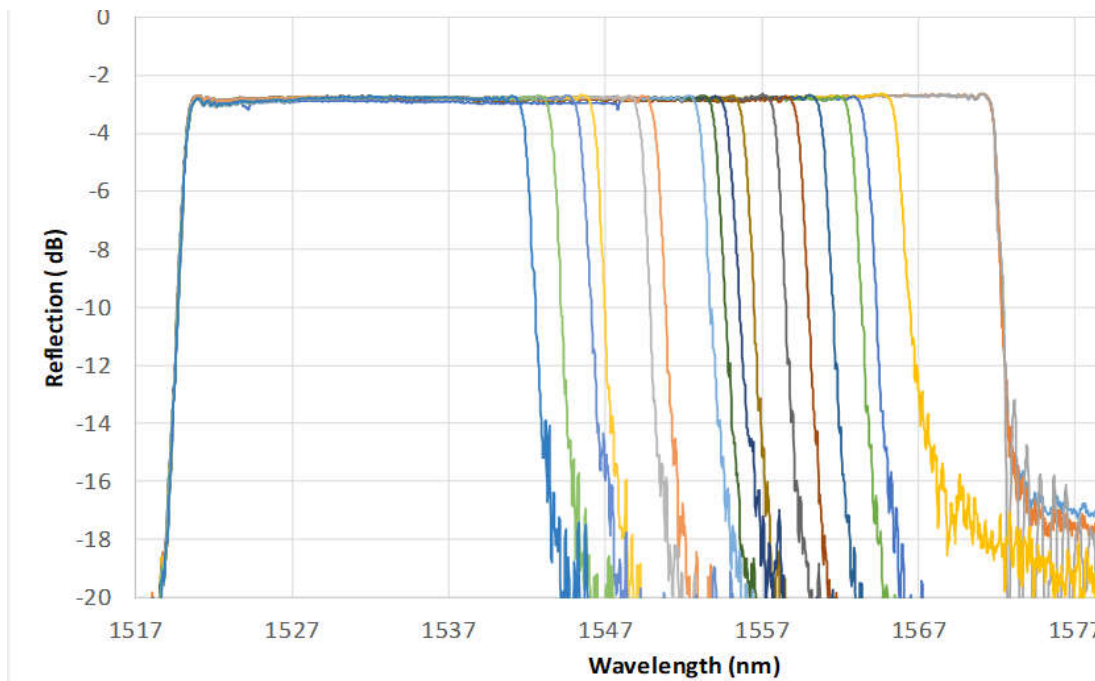

Figure 6. Example of plateau Chirped FBG reflection after different cuts, starting at the highest wavelength

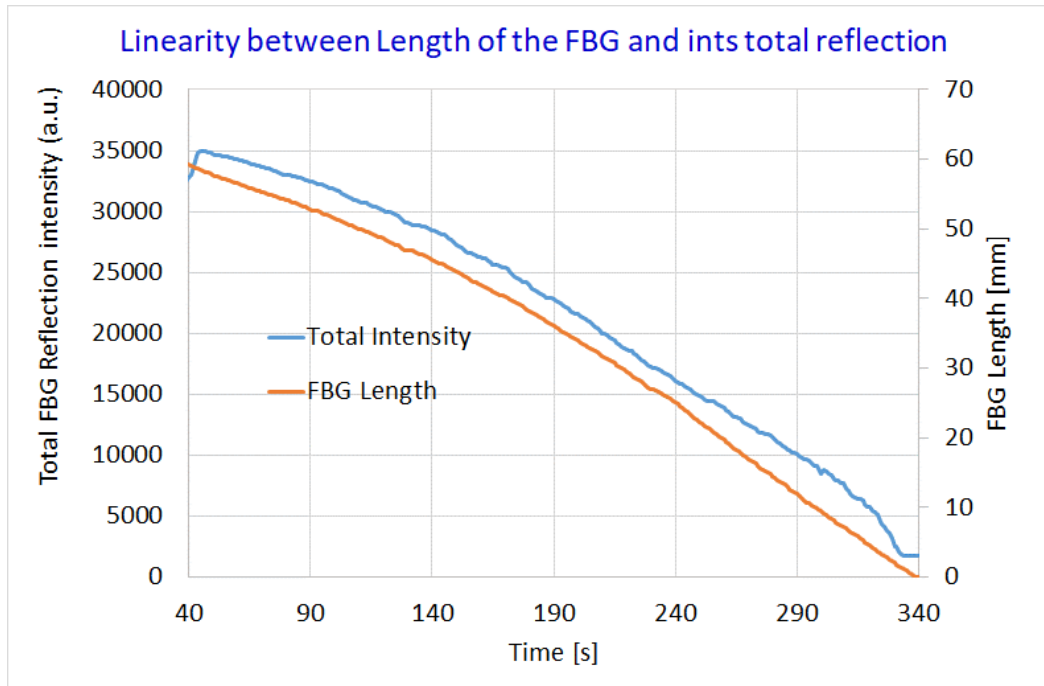

Figure 7. Linear relationship Wavelength vs its position on the grating and Linear intensity vs FBG lost part

3. EXPERIMENTAL RESULTS

Representative results are presented using for an example (Figure 8):

- Four layers Kevlar and epoxy
- Fiber sensor in the middle
- Strain Gauge on the back side

The debris simulants are 2 mm diameter stainless steel spherical pellets launched at 1.5 km/s

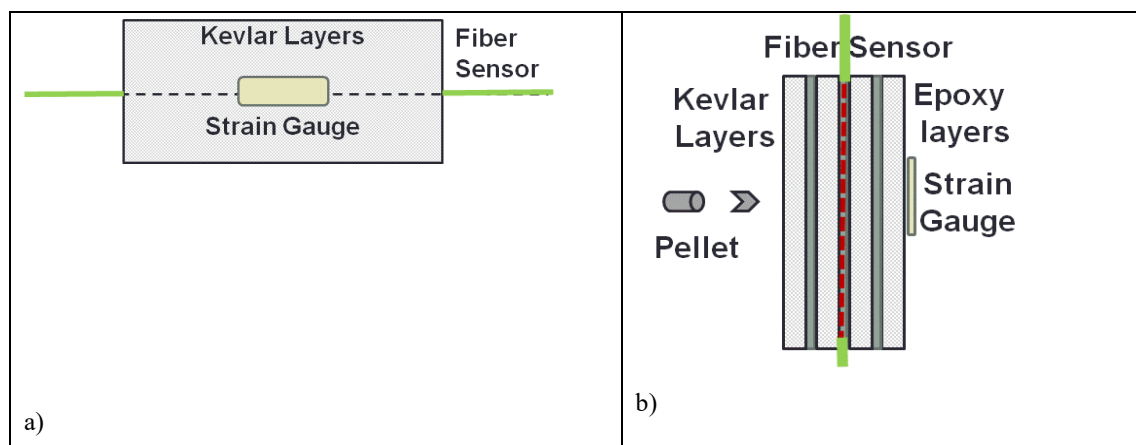

Figure 8. Four layers Kevlar/Epoxy, a) Top Front View; b) Cross Section Side View Strain Gauge and FBG (example Shot #79)

The measurements are presented in the following figures

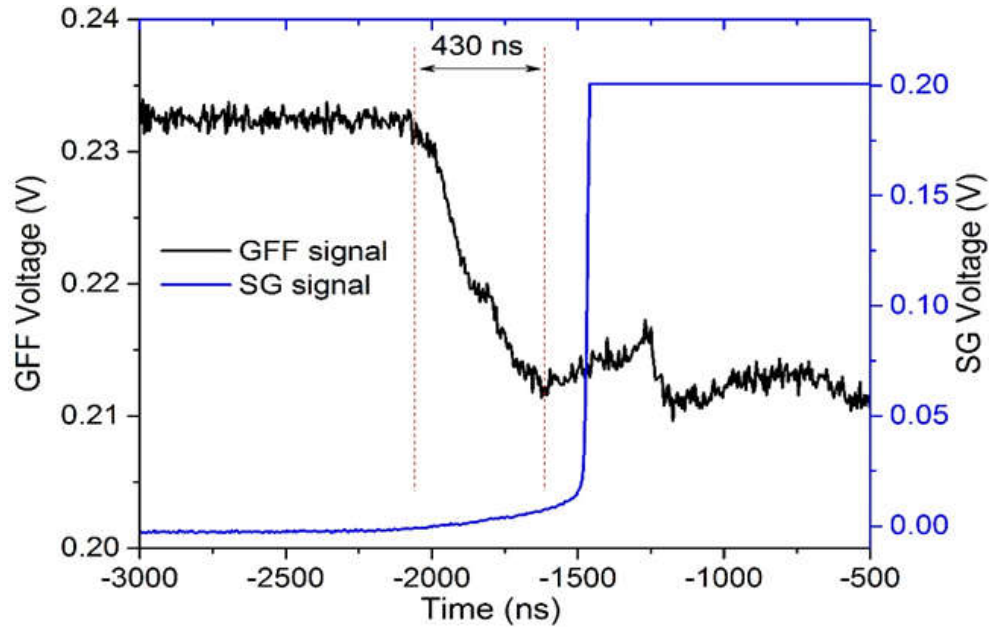

Figure 9. Fast Response of the FBG (called GFF) and the Strain Gauge (SG)-

We can see in Figure 9 there is 430 ns delay between the response of the FBG and Strain Gauge due to the few mm thick layers that the pellet has to pass between the fiber and the Strain Gauge.

Figure 10 and Figure 11 show the complete FBG reflected spectra before and after the impact. The impact breaks a small part (1.2 mm) of the fiber, as can be deduced from the missing part of the spectrum. The left and right side show strong stresses after the impact, with some recuperation (healing) after 86 days.

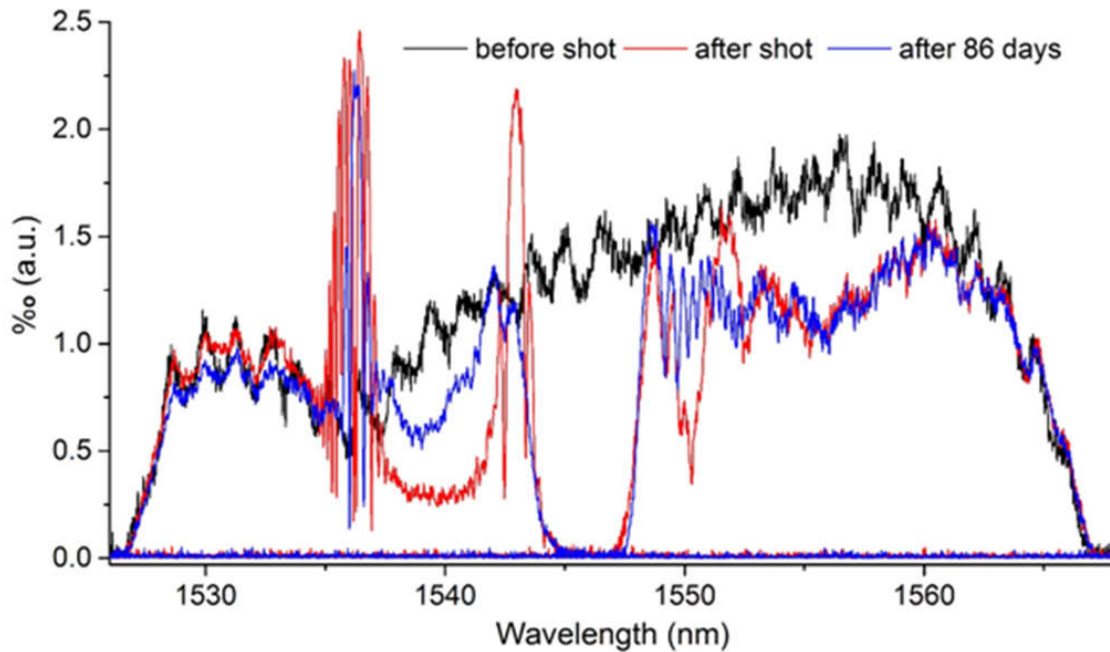

Figure 10. FBG spectra before the impact (black), the empty part in the middle is the broken part, the red graphics are the FBG spectra (left and right side) just after the impact, the blue graphics are the FBG spectra (left and right side) after 86days.

The left side has two local residual stress (peak intensity) the stress is reduced with time.

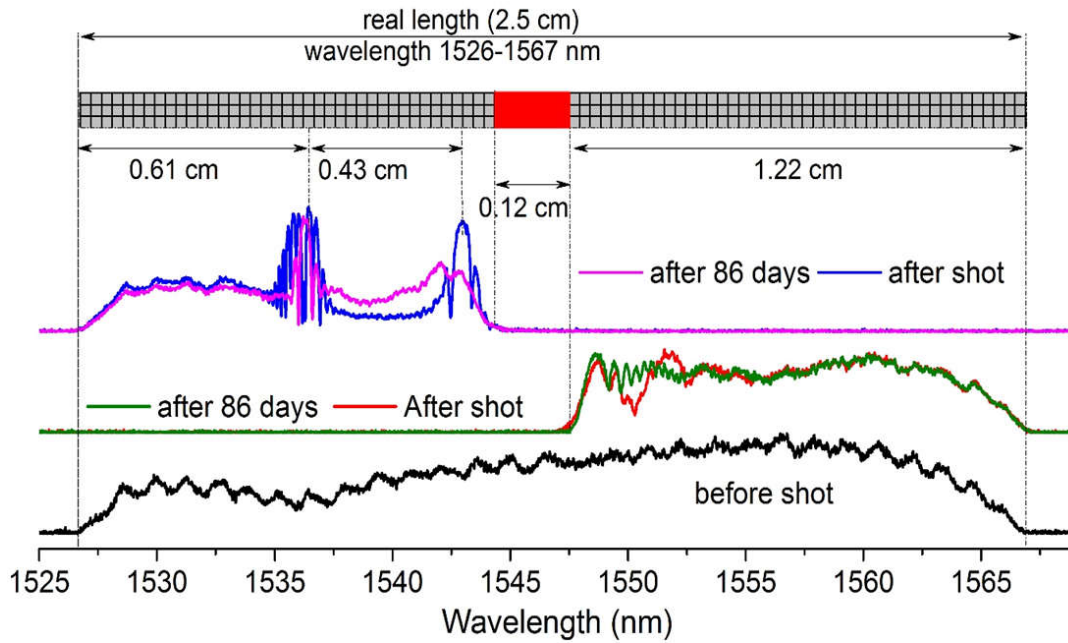

Figure 11. Spectra of the FBG before and after impact traced in cascade for better clarity

Figure 12 and Figure 13 show the results of FBG single wavelength and Strain Gauge Fast Acquisition (Shot #75). The Strain Gauge behind the 4 layers responds 250 ns after the FBG in the middle of the layers

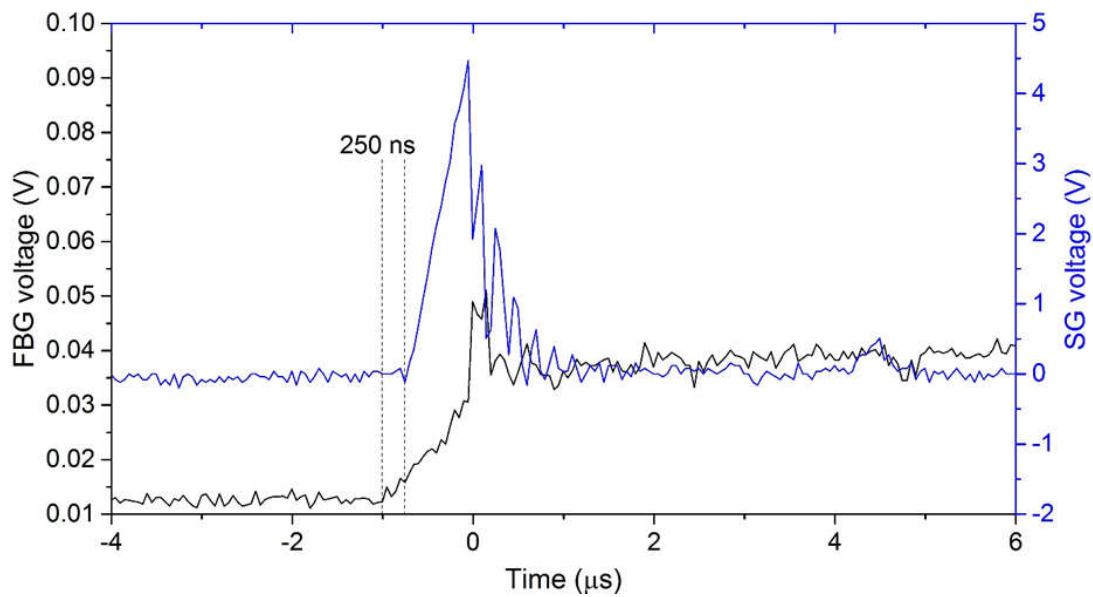

Figure 12. Fast Response of the FBG (single wavelength) and the Strain Gauge (SG).

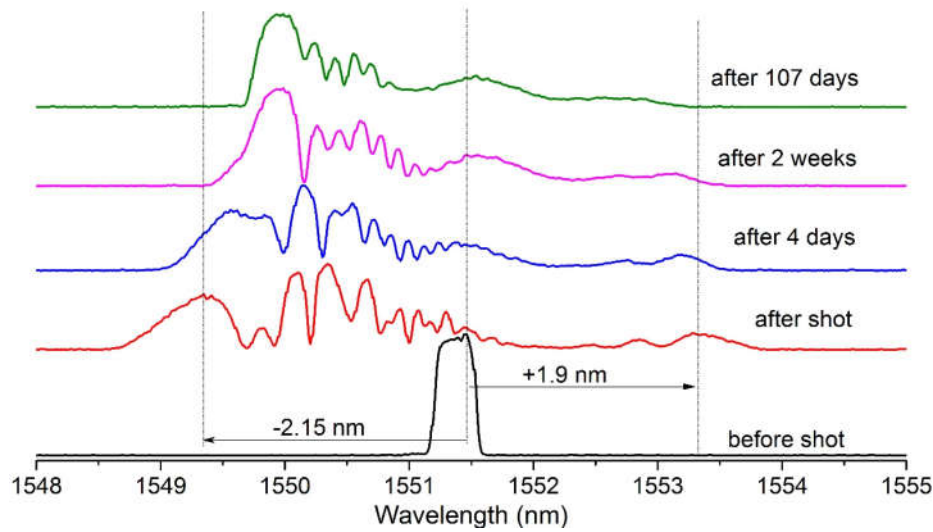

Figure 13. Spectra in cascade, of the single wavelength FBG before and after the impact- we can see some recuperation with a permanent induced stress (wavelength shift)

Table 1. Shot #75 strain details measured just after the shot from the multi CWL shifts

(Negative shift in wavelength = stress; positive = extension)

Initial peak	Shifted peaks	Pressed	Strain	Extended	Strain
(nm)	(nm)	$\Delta\lambda$ (nm)	$\Delta\varepsilon$ (%)	$\Delta\lambda$ (nm)	$\Delta\varepsilon$ (%)
1551.4	1549.3	-2.1	-0.173		
	1549.8	-1.6	-0.132		
	1550.1	-1.3	-0.107		
	1550.3	-1.1	-0.091		
	1550.6	-0.8	-0.066		
	1550.9	-0.5	-0.041		
	1551.0	-0.4	-0.033		
	1551.3	-0.1	-8.2E-03		
	1552.4			1	0.0823
	1552.8			1.4	0.1152
	1553.3			1.9	0.1564

The physical size of the single wavelength sensor (FBG length) is about 10 mm We cannot identify where exactly the pellet hit, however, we can identify the values of a few local strains, without identifying their position.

In the chirped FBG we could identify the local position of the strains however without knowing their values, only a qualitative idea is provided with the change of the reflected intensity.

4. HEALING VERIFICATION

4.1 Test in Vacuum

The healing hermeticity is demonstrated by testing the Kevlar-EMAA multilayers in vacuum. The multilayers were hermetic in vacuum at 10^{-6} Torr. Figure 14 shows the detailed SEM images of the impact and healing of the Kevlar-EMAA multilayers

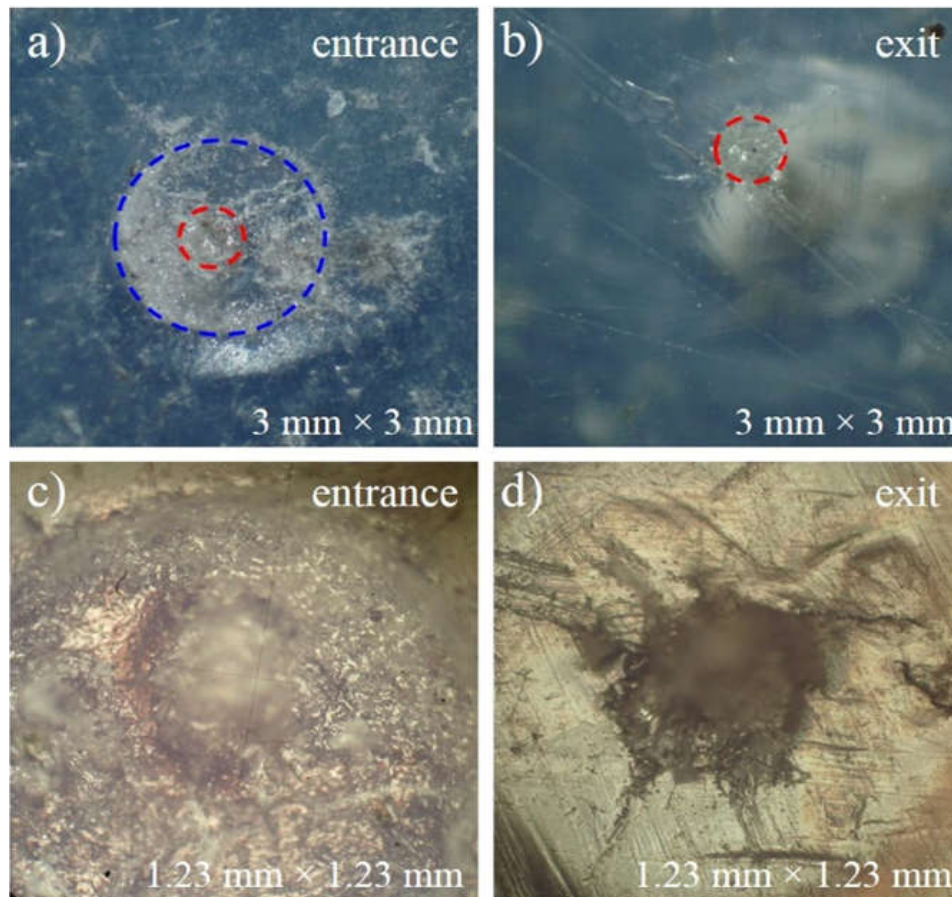

Figure 14. a) the bullet entering side after impact; b) the bullet exiting side after impact; c) and d) are enlargements of a) and b) The red circle indicates the influenced area at the entering side, The blue circle indicates the exiting side.

4.2 X-ray Computed Tomography.

The X-Ray Computed Tomography measurements were performed at ESTEC/ESA Test Center. The images were obtained over 360° with micrometric resolution. The scans set up was with 104 kV and 155 μ A. Post-measurements softwares provided by ESTEC-Laboratory are used for assembling all images together in a 3D volume rendering.

The X-rays-Computed Tomography image permits to see the EMMA was healed, and to follow the pellet trajectory through the Kevlar that does not heal (Figure 15).

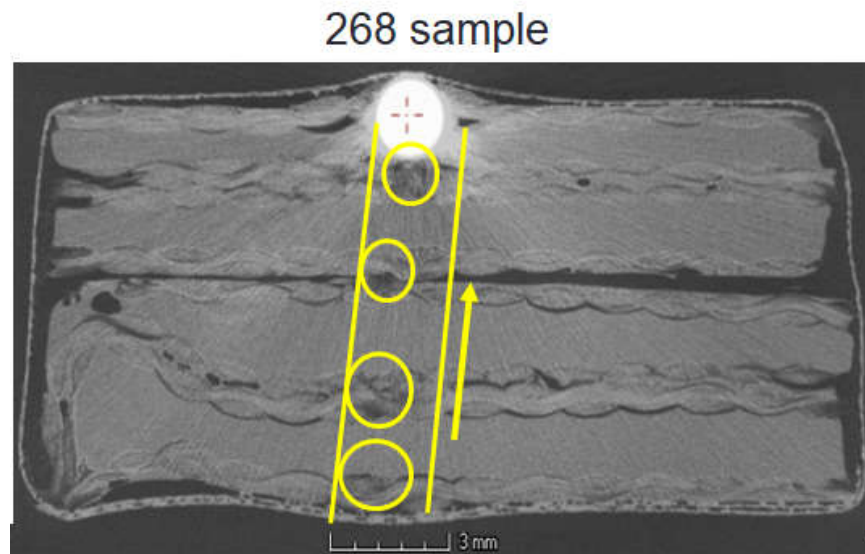

Figure 15. X-rays-Computed Tomography image of an impacted Kevlar-EMAA multilayer

5. CONCLUSIONS

The conclusions are summarized with the following:

- Combining layers of Commercial Materials are efficient as self-healing layers of COPV
- The combination should contain strong materials layers (Kevlar, Nextel, ...) and self-healing materials (e.g. Surlyn EMAA)
- There are innovative potential applications of fiber sensors to monitor the small debris impact
- Fiber sensors can monitor very fast events at the ns level
- Fiber sensors can monitor the evolution of impacted material before and after impact at a slow time level
- Selecting an optimal combination of materials EMAA, Kevlar/Nextel and Resine would be the best method to protect the COPV tank. More work to be performed in this field
- The hypervelocity is lower than many space debris- the current projects demonstrate the feasibility for a next step with higher velocity and complete cover of the COPV

ACKNOWLEDGEMENTS

The authors would like to acknowledge the support of:

- Dr. Darius Nikanpour (CSA) for his assistance during this work.
- Prof. Federico Rosei INRS-EMT director for his continued assistance by providing Post Doctoral fellows and Ph.D. Students to work on the project.
- Prof. Andrew Higgins, McGill University, for providing the double stage launcher with all the technical information and support, that permitted us to perform the experiment at MPB locations.